



The Winchester and Portsmouth Diocesan Guild of Church Bell Ringers

(Formerly Winchester Diocesan Guild, Founded June 26th 1879)



(Belfry Stewardship Committee)

Guild-wide Survey of Church Bells & their Fittings

Notes for Guidance on Completing the Survey Forms

This document and the accompanying Survey Report Form are designed to enable parishes in the two dioceses of Winchester and Portsmouth to provide information for a "Guild-wide" survey of church bells and belfries. These Notes for Guidance explain why the survey is taking place, and how the survey form should be completed.

Why are bells important?

Almost every church in the two dioceses has at least one bell - in accordance with Canon law. Bells are unique and valuable items of the equipment of any church, not least because of the costs, and skills involved in their manufacture and hanging. Since many of our local bells date from around the time of the reformation, and in some cases from many years before, they, together with the bell-frames in which they may hang, are also frequently important historical artifacts. Through their design, construction or inscriptions they are often valuable sources of information about the past history, personalities and crafts of a parish or locality.

Above all, in use, church bells proclaim the Gospel of the Risen Christ in a way that reaches and touches the lives of all who hear, whatever their faith or position. The message of the bells is not one that can be easily ignored!

For all these reasons our church bells are worthy of conservation and maintenance in a sound condition and in good working order. If for no other reason, the sounding of a bell before Services is a clear message that the local church is alive and that God is being actively worshipped in that place.

So, in this Decade of Evangelism, the Guild of Bell Ringers for the Dioceses of Winchester and Portsmouth have determined to re-invigorate their own ministry with a new and more pro-active role in fostering the care and maintenance of the bells upon which they "evangelise".

For many years the "W&P" has provided grants from its Bell Restoration Fund to support parishes engaged in the repair or restoration of their bell(s). Now, in a renewed spirit of stewardship, Guild members are making even greater efforts to raise funds to support this work. In addition we have formed a **Belfry Stewardship Committee**, who will take an active lead in the practical aspects of promoting the care, maintenance and conservation of all local bells in good working order.

So - Why is a Survey of Bells Necessary?

In order to fulfill its aims effectively, the Guild, and particularly its Belfry Stewardship Committee, needs reliable and up-to-date information about the "stock" of church bells in the two dioceses, and about their condition - all bells, from single service bells in small country churches to the great rings of 10 and 14 in our mighty cathedrals of Portsmouth and Winchester respectively.

The last [incomplete] inventory available for the mainland and Isle of Wight (Hampshire Church Bells) was published in the early 1920s. There are later works for some of the Channel Islands but even here some time has elapsed since they were published. Many new bells have been added since these works first appeared. Others have been recast. New peals have been hung, while elsewhere restoration and repair have given old installations a new lease of life. In some cases bells (including complete rings) have been lost by sale or war damage - sadly some have become neglected or unusable through financial considerations, or perhaps because of a lack of relevant local knowledge about their upkeep.

This new survey will give the Guild a complete and up-to-date picture. It will help to identify how much maintenance or restoration work is likely to be needed over the coming years, and aid in determining the level of grant funding that may be required from the Guild's Bell Restoration Fund to support this. It will also help in the planning of active, practical support to parishes wishing to maintain or restore their bells or belfries. And it will focus on those churches where practical help can prolong the working life of existing equipment thereby saving valuable resources for other important aspects of ministry.

The survey will also provide the source material for a revision of the existing out of date reference works.

We do hope that your parish will support this venture and help us by returning the completed form as quickly and as accurately as possible. Please feel free to take a copy of the information that you gather for your own church or tower records. Where there is any difficulty in describing the situation with your particular bell(s) or fittings, please take the opportunity to provide any additional drawings, sketches, photographs or other material that will help clarify the position, and perhaps help us to identify a previously unrecorded, historical bell or bell frame.

We thank you for your support.

About the Survey Report Form

The enclosed Survey Report Form has been designed to "standardise" the information that is required, and to act as an aide memoire for the compiler, helping to ensure that a full picture of each church's bell(s) can be obtained.

It is hoped that the form, if completed in accordance with the following notes for guidance will be self explanatory. However, in the event of uncertainty, please contact the Guild at the address on the last page of these notes.

The form is in two parts -

Part 1. An A3 folded document that seeks information about:

- The church
- The bell tower, belfry or bell cote
- The bell frame if the bell(s) are hung in one
- The bell(s) in general terms
- A general description of the bell installation covering its condition, state of repair, how and when the bell(s) are rung, plus any other relevant information on their maintenance and or previous/planned restoration or repair.
- Details of any historical ringing records - peal boards etc. hanging in the church or tower, which are worthy of preservation as historical records of the progress of bells and ringing within the guild area.

Part 2. An A4 sheet, one per bell in the church, seeking detailed information on each bell, its origins (founder), size, note, inscription and its fittings and hanging.

NB: You should have one "Part 1" folded sheet and sufficient "Part 2" sheets for each of your bells. If there are insufficient Part 2's please photocopy additional copies. Thank you.

How to Complete the Survey

The following notes will explain what is required in each section, and will illustrate how the form should be completed:

PART 1

Section 1 - Details of Church:

General: This section is intended to provide a pen picture of your church - the setting for your bells. Where it is, and who we should contact in the event of any queries with the survey or about your bell(s).

Principal Contact: Please enter the name of the person who normally deals with correspondence about your bells - e.g. Your Tower Captain/Tower Secretary or perhaps the Compiler of this Survey, or a Church Warden etc.

General Description of Church: What is needed here is a brief description of the church, typically a short precis of your guide book - for example your comments might be along the lines of:-

"Typical downland church of brick and flint with low nave, north aisle, chancel and timber framed bell cote rising

above western nave roof, from massive oak supports. Nave XII to XIV centuries - chancel rebuilt circa 1875. Whole church, and particularly bellcote and supporting timbers subject to major restoration in mid 1970's." etc.

Sketch/photo of Church: . . . (just to give us a picture of the church building).

Section 2 - Details of Tower/Belfry:

General: This information will help us understand where the bell(s) are hung. While the condition and structural safety of all bell towers and bell cotes is of direct relevance to the safe swinging of bells hung in them, this information is particularly relevant for typical Hampshire timber-framed bell-cotes and belfries in assessing the safety of the tower structure for bells hung for full circle ringing to continue to be rung in that fashion.

Position within Church: typical answers might be e.g.: "*Western tower abutting west end of nave*", or "*single bell arch over east gable of nave*"

Construction materials: please describe what the tower or belfry is made of - e.g.: "*Flint rubble with Ashlar quoins and coursing bands*" or "*Oak weatherboarding over mediaeval oak frame-work supported on oak roof trusses.*"

Access to bells: Please describe how the bells are reached - very important if any future survey or inspection is required! - e.g. "*stone spiral stairs from inside south west corner of tower - access off to all floors and roof*" . . . or perhaps "*20 foot extending ladder (not available in church) required from nave floor to trap door in centre of belfry floor (over nave) direct to bell chamber*" . . .

Type: Please use the following descriptions to aid your choice -

Tower - a structure of timber or stone rising from either the ground, or supported from pillars/piers or supports that are an integral part of the church building -(as in the case of a central tower supported by the arches of the "crossing").

Turret - a stone or timber structure forming an upper extension to another architectural feature - such as the upper tier of an ornamental pillar or enlarged pinnacle. Often primarily an architectural feature that contains bell(s) by "convenience"

Belfry - a small timber or stone construction sitting on, or rising from the roof of a nave or aisle, often of timber-framed construction; may be supported by the roof trusses or by structural uprights rising from ground level.

Bell cote - a small arch or ornamented "box-like" construction usually above and supported by a roof ridge or gable, usually designed and built for the purpose of housing bells.

Other - please use this option to identify any "bell location" not easily described by the foregoing categories - please add a clarifying description if the nature of the structure is not clear from other information in the survey.

North/South cross section: as illustrated below -
East/West cross section; as for example -

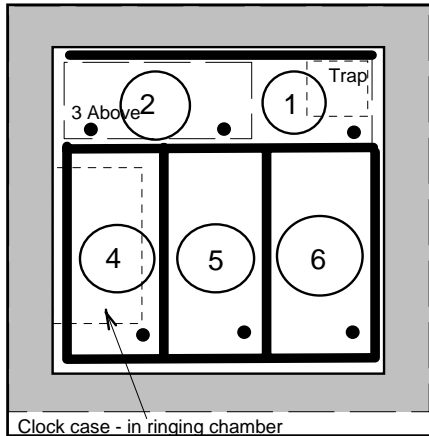

Sketch Plan of Tower/belfry: what is required here is a diagram as illustrated:

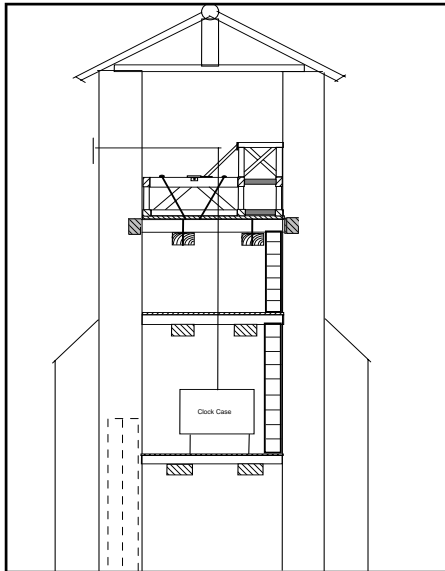

N

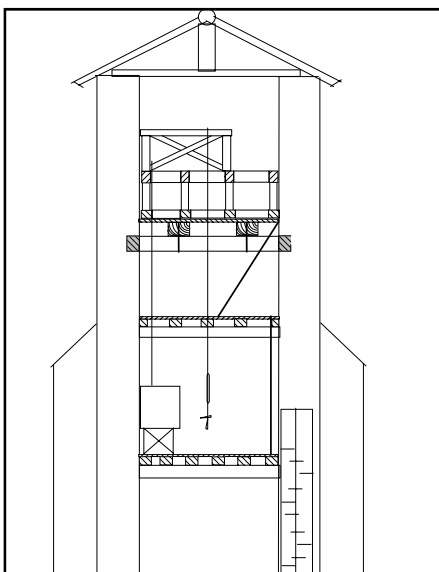

General Description including Condition of Structure:
 what is required here is a pen picture of the tower/belfry and its general condition, including, for example, obvious evidence of weakness, damage or decay, signs of major repairs, soundness of floors and other aspects of the overall condition of the tower/belfry.

Section 3 - Details of Bell Frame:

General: This section is designed to provide a detailed description of the structure in which the bells actually hang. (Obviously if the bell(s) are suspended directly from the uprights of a turret or bell cote, for example, simple information on the hangings will suffice). Gathering fuller details of older bell frames is becoming increasingly important with moves to "schedule" or "list" historic frames worthy of preservation, in the same way that some historic bells and other church artifacts are "listed". Hence comprehensive information in this section will provide important information in helping to identify such installations.

Material: Please tick the relevant box or indicate alternatives in the space provided.

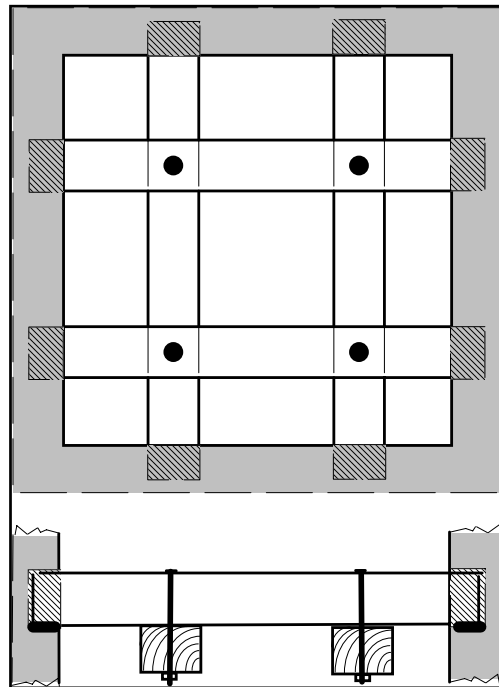

Sketch plan of Foundation Supports:

What is required here is much fuller detail of the structures UNDER the bellframe, supporting it, e.g.:

Timbers - 12" x 10" Oak, resting in recesses in tower wall, with slate pads between beams and masonry. All intersections of timbers bolted through.

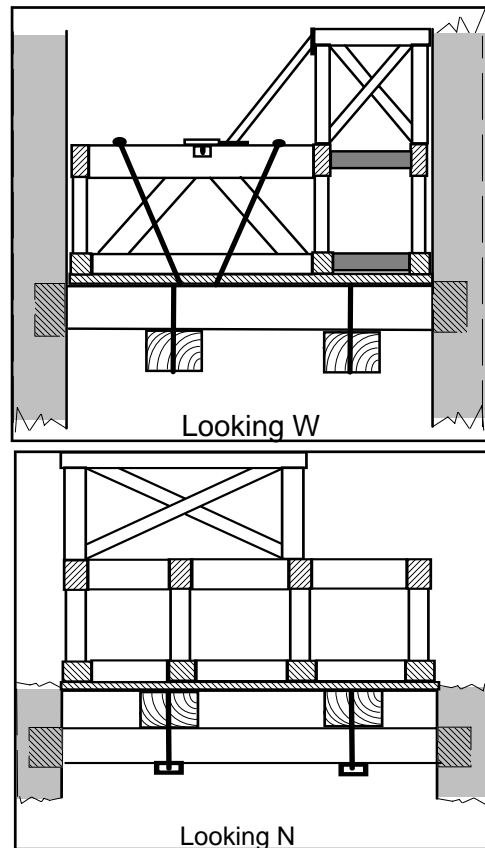
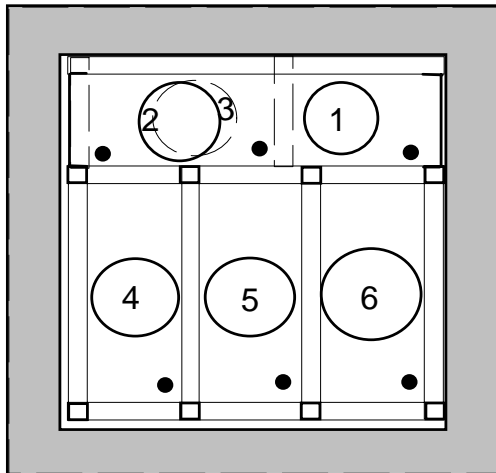

Sketch Plan of Bell Frame: This should be a much more detailed diagram of the bell frame installation than given in the general overview of the tower at section 2: e.g.:- Pit ends to 1 & 2 are iron strapwork -1/2" x 5"

Sketch Diagram of Typical Truss: What is required here are cross section(s) of the bell frame showing (particularly for timber frames) the design and shaping of the timbers forming each "frame-side" or "truss", and indicating where any modifications, strengthening, tie rods, angle plates etc. have been fitted. It is particularly

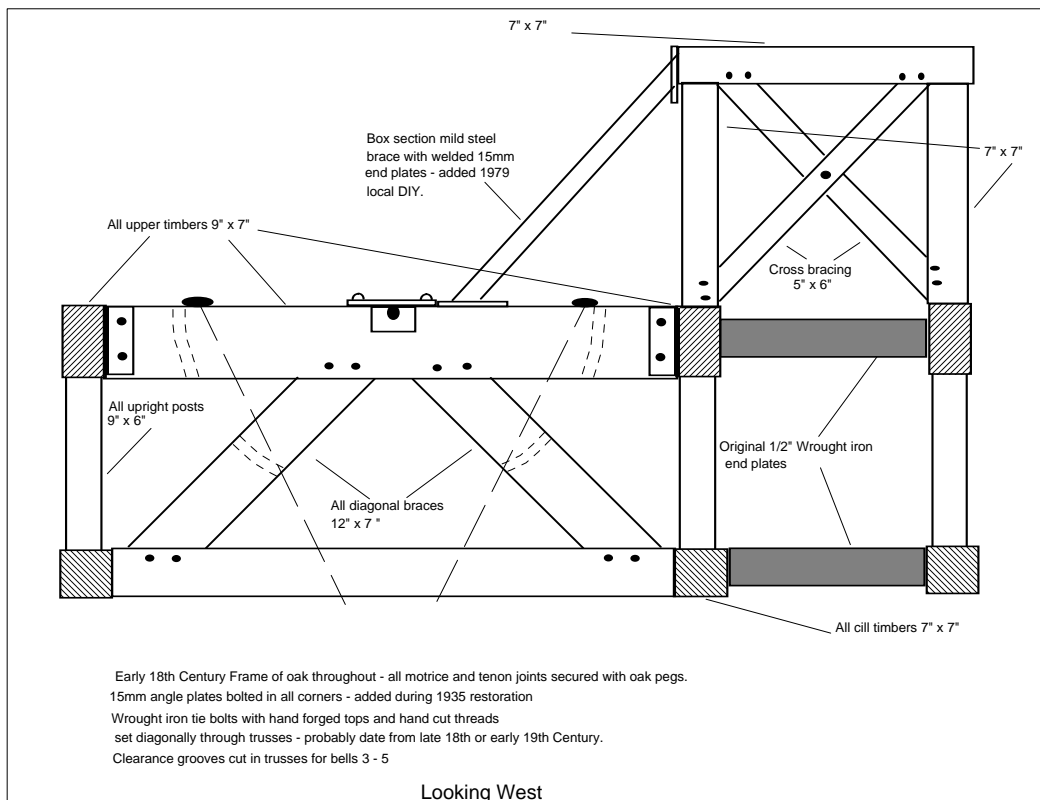

important to identify old mortices, and other working of the timbers, joint peg positions, additional timber spliced in or added etc. e.g.:

Please provide fully dimensioned diagrams and cross sections to describe each different aspect of the bell frame. Photographs and three-dimensional sketches may also be useful to explain details of more complex frames.

Please use additional sheets of paper for diagrams if necessary.

Section 4 - Details of Bells:

General: This section provides for basic information about the number of bells in the tower, and an indication of the size of the ring, based on the weight and note of the tenor (largest bell).

Section 5 - General Report on Present Condition of Installation:

This section is intended to provide a "layman's pen picture" of the bell installation overall, based upon simple observation. It is intended that the section should focus on the tower and bell frame more than the bells and their hangings which are detailed in Part 2 of the survey. Comments should include details of, for example:

- indications of the age and origins of the installation if possible, together with details of any repairs or restorations and their effect
- the general well-being of the equipment
- evidence of decay or infestation, rust or corrosion of the bell frame;
- evidence of damage to either the tower or the bell installation through use of the bells, or as a result of other circumstances.
- presence of bird or other debris
- any other information that would complete a pen picture of the belfry.

This section should also be used to describe known past restorations, recastings etc. And should include an indication of the extent to which the bell(s) are actually used

Section 6 - Peel Boards:

Completion of this section should be self explanatory and is intended to help the Guild identify those records ringing activities that are of historical importance to either the local Church, the progress of ringing within the Guild area, or the progress of ringing on a wider plane. While this section will generally refer to records of actual ringing, other records associated with the art of ringing may be included if deemed appropriate. Where possible, sketches, photographs or other documentary records of the content of these Boards should be included in the survey to aid later reference.

PART 2

One copy of Part 2 should be completed for each bell in the church, including disused and "unhung" bells.

Tower: In order to assist in collation of the survey, and to avoid loose pages becoming separated from the main report, please record the name and dedication of the church in the space provided.

Details of Bell No: Please use the numbering convention where the smallest bell (treble) is number 1, and the numbers increase in sequence to the largest (tenor) bell. Sanctus or "Sauce" bells "outside" a ringing peal should be indicated "S"

Diameter: Measured in inches across the mouth:

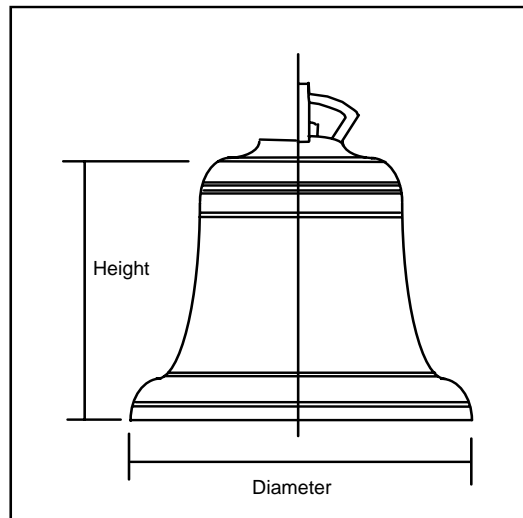

Height to shoulder: Measured in inches, vertically from the lip of the mouth to level with the shoulder - viz:

Weight: Please provide accurate weights in Cwts., Qtrs. and Lbs., if available, or else estimated/reputed weights for each bell.

Note: Please enter the "strike" note of the bell.

Founder/Date: Please enter the founder of the bell and the date of last casting -(reputed if not known precisely)

Canons: These are the hanging loops cast on the crown of older bells. Modern bells are predominantly flat-topped, in which case please reply "none". Please strike out those options which do not apply.

Bell Turned: This will usually be indicated by the presence of more than one pair of immediately opposing clapper indentation marks inside the soundbow (upper mouth) of the bell. Bells that have been turned once (quarter turned) will have two sets of indentations at right angles to each other. Further turning (usually of very old, or very regularly used bells will create additional pairs of marks at 45 degrees. Bells with cannons that have been quarter turned can also be detected if two canons project out from the base of the headstock, rather than one.

Casting: A **good** casting is one where the surface of the bell, inside and out is smooth and even, all the

lettering and founder's trade marks and ornaments are crisp and clear, and overall the bell is of "pleasing" appearance. A **poor** casting will have, for example, a rough surface, with evidence that the mould was not properly smoothed, the surface may be pitted or flawed, and letters and "stamps" may be poorly marked and or difficult to read. A subjective guide is all that is required here.

Canons: For bells that retain their canons, please indicate any ornamentation on the outer surface -

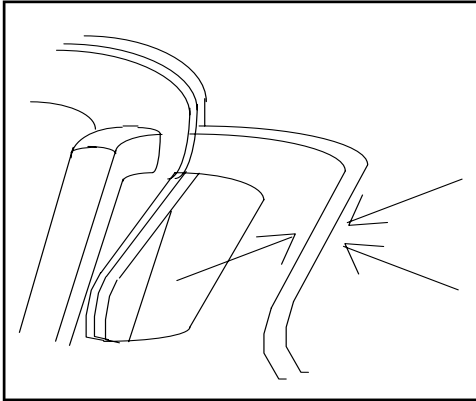

Ribbed - indicate "R" - ribbed canons have a raised section in the centre of the outer face:

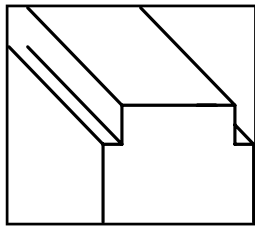

Cabled - indicate "C" - cabled canons have a "rope-like" pattern or intertwined ornament on the outer face:

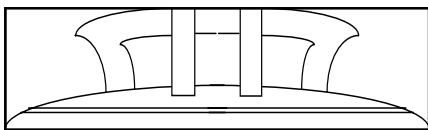

Doncaster - (Warner) - applies only to bells cast by John Warner in the late Victorian period with low "flat, angular canons:

Doncaster - (other) - applies to this style on bells cast by any other founder - they may reflect the pattern above or, for example may be similar to the design below:

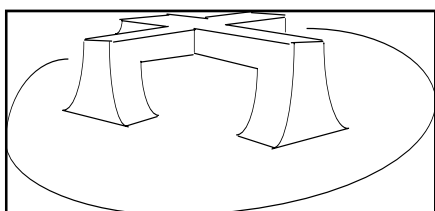

Tuning: To establish whether, and how a bell has been tuned, it is necessary to inspect the inside surface. If this surface, above the soundbow right up into the crown of the bell shows no sign of any mark other than the minor blemishes of the casting, then it is a "maiden" bell and has not been tuned. Please tick "none".

If the bell shows evidence of a series of vertical grooves chiselled into the metal around the inside of the waist, then it has been "chip" or "chisel" tuned by hand, using a hammer and chisel - please indicate a tick against "Chip/chisel". If the bell shows signs of a smoothed, machined surface, or a series of parallel striation touching each other and running around the bell, often right up into the crown, then it has been tuned on a vertical boring lathe designed for the purpose. Please indicate a tick against "machined". It is quite possible for old bells to have been chip tuned originally then retuned in modern times by lathe. An entry in both boxes is valid here.

In some cases, rather than tune inside the bell to flatten it's note to the desired tone, a bell may have been "sharpened" by chipping, filing or machining away part of the rim. In this case the bell has been "skirted" - please tick if there is evidence of this - all around the rim.

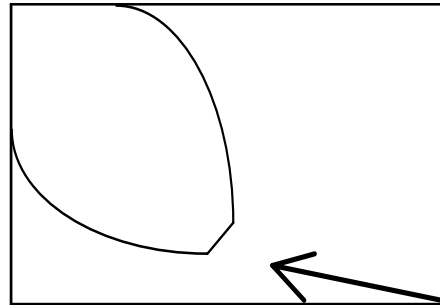

NB: Please do not be confused by the odd chip missing from a bell rim through accidental damage - bell metal is brittle and the rim is the most likely point to suffer damage of this sort.

Crown Staple: This is the piece of equipment from which the clapper is suspended. Until the beginning of this century the crown staple was "cast-in" - i.e.: A piece of wrought iron was shaped rather like a stirrup and set in the bell mould so that when the bell metal was poured, it encased the top of the staple, holding it firm in the crown of the bell, leaving the "stirrup" section to suspend the clapper. Cast in crown staples can rust and on expanding crack the crown of the bell. This section will help identify where such bells remain, and also identify bells where a "false" crown staple has been fitted to an old bell - similar to:

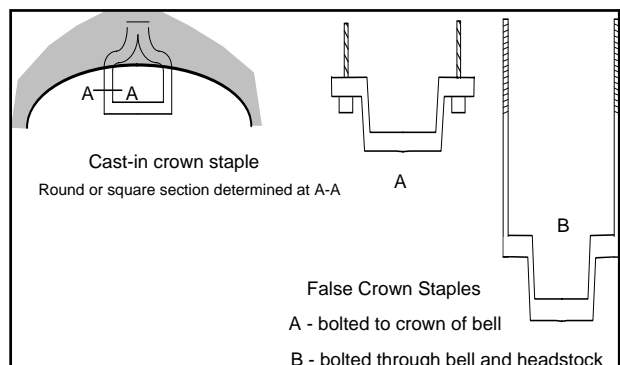

and where a modern "independent" staple is fitted - viz.:

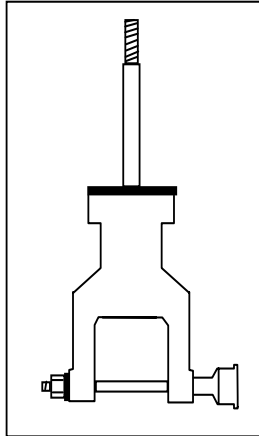

NB: where there is evidence of stumps or stubs of old cut-off or broken crown staples remaining within the crown, please insert "S" in box against relevant "cast-in" entry in lieu of a "tick".

Clapper Indentation: What is required here, for each pair of clapper indentation marks inside the soundbow is a measurement of the greatest depth of the impact depression. Even though the clapper no longer strikes on an old indentation due to quarter or eighth turning, deep indentations can still indicate a seriously weakened bell with increased risk of cracking in use. The earliest (initial) strike marks should be entered in the first box, with the latest (current) marks as the last (second or third) entry as appropriate.

Is Bell Cracked?: Answers may be subjective unless there is clear, visible evidence. A description and if possible indications on a diagram of the location and extent of cracks is desired. Particular care should be taken to determine evidence of crown cracking due to expansion of cast-in crown staples or staple stubs.

Inscription: What is required here is full details of the lettering, text and ornamentation on the bell's surface, together with indications of the location of each mark.

Please pay particular attention to the shape and style of lettering and to "trade marks" and ornamental "stamps" that are vital in helping to identify the founder of otherwise "anonymous" bells. Please note that some mediaeval inscriptions are in archaic lettering. If necessary clear "brass rubbings" of inscriptions will help determine the text content and founder's alphabet.

Details of Fittings: The following numbered diagrams should be used to indicate generic fitting types. Please enter the number of the design corresponding most closely to the component for the bell. In some cases it is necessary to indicate a combination from the examples shown: e.g.: 1B for a combination of stirrup headed clapper with flat faced flight. Where there are particular variations from the design shown here, (e.g: clapper head, slider mechanism etc.) these should be illustrated in the accompanying diagrams and sketches, supplemented by photographs where appropriate. If a particular component appears never to have been fitted please mark "X" in the appropriate box. If a component appears to have been fitted once but is now missing, please mark "M".

Headstock:

Type 1



Timber - simple block

Type 2

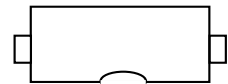

Timber - with high bosses

Type 3

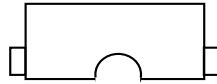

Timber - with lower bosses

Type 4



Timber - with bosses at lower edge of stock

Type 5

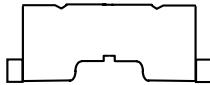

Timber - with bosses at lower edge of stock enlarged canon recess and strapwork retaining recesses

Type 6



Timber - Modern (20th C) simple block shape

Type 7

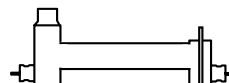

Cast iron - square and hollow box section

Type 8

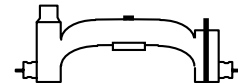

Cast iron - arched hollow box section

e.g.: John Taylor & Co of Loughborough

Type 9

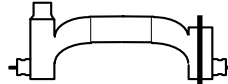

Cast iron - arched, hollow centred canon retaining hollow box section with central open "well"
e.g.: John Taylor & Co of Loughborough

Type 10

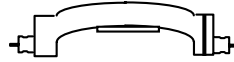

Cast iron - arched hollow box section

Type 11

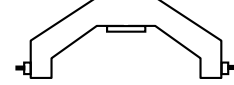

Fabricated and galvanised steel Canon retaining

e.g.: Whitechapel (formerly Mears and Stainbank)

Type 12

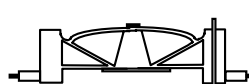

Cast iron - braced web

Type 13



Cast iron - braced web with canon retaining open "basket" centre

e.g.: Eayre and Smith - Kegworth

{Headstock} Strapwork (for timber stocks only):

Headstock top plate ironwork:

Type A



Hand forged "cotterill" (washer/spacer)

Type B

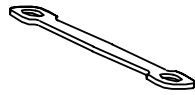

Early hand wrought iron plate

Type C

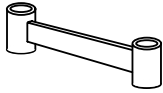

Victorian forged "stretcher and tube" pattern

Type D

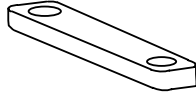

Victorian/modern hand wrought, iron plate

Type 11

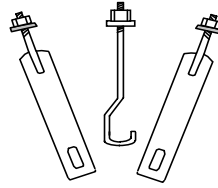

Hand wrought iron strap with machine-cut threaded top and pierced end, and with machine-cut threaded top "J" strap

Type 12

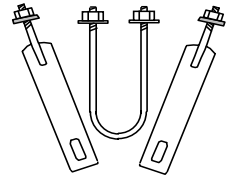

Hand wrought iron strap with machine-cut threaded top and pierced end and machine-cut threaded top "U" bolt

Headstock Strapwork

Type 1

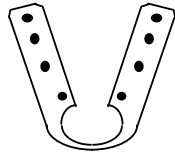

Nailed Sheerbands - around canons and nailed directly onto headstock.

Type 2

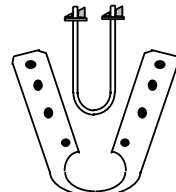

Nailed Sheerbands - and "eyed" "U" truss with key wedges through headstock and around central canon

Type 13

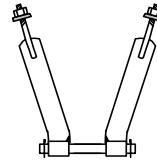

Hand wrought iron strap with machine-cut threaded top, rolled ends joined by round bar - used with quarter turned bells

Type 14

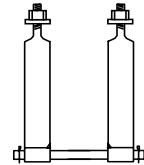

Modern, straight profile, hand wrought iron strapwork with threaded top, and rolled ends joined with round section iron bar - used with quarter turned bells

Type 3

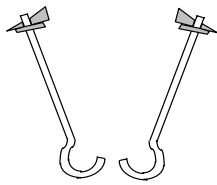

Slotted eyed "Lynce pin" and key "J" strap.

Type 4

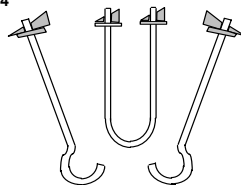

Slotted eyed "Lynce pin" and key "J" strap with eyed "U" truss

Type 5

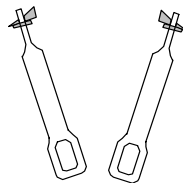

Hand wrought iron strap with slotted eye, key and pierced end

Type 6

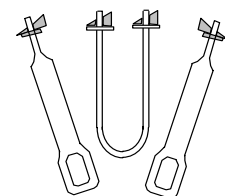

Hand wrought iron strap with slotted eye, key and pierced end with eyed "U" truss

Type 7

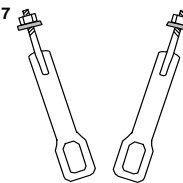

Hand wrought iron strap with hand-cut coarse threaded top and pierced end

Type 8

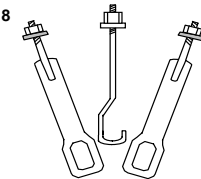

Hand wrought iron strap with hand-cut coarse threaded top and pierced end, and with hand-cut threaded top "J" strap

Type 9

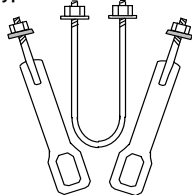

Hand wrought iron strap with hand-cut coarse threaded top and pierced end and hand-cut threaded top "U" bolt

Type 10

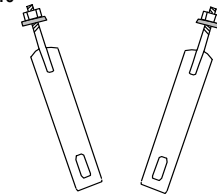

Hand wrought iron strap with "machine cut" threaded top and pierced end

Gudgeons:

Type 1

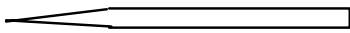

"Drive in" gudgeon, impaled directly into end grain of timber headstock

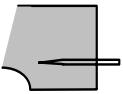

1A - without headstock boss

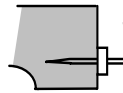

1B - with headstock boss and stock hoop

Type 2

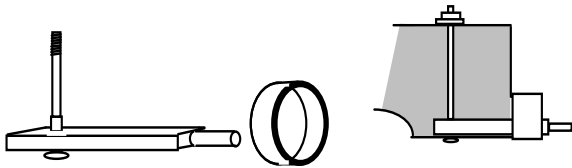

Strap gudgeon with tail bolt and stock hoop - fitting into mortice in underside of headstock

Type 3

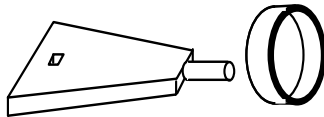

Dovetail strap gudgeon with tail bolt and stock hoop - fitting into mortice in underside of headstock

Type 4

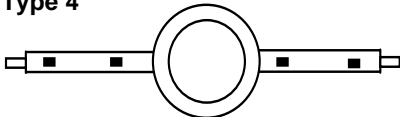

Double ended "Hoop gudgeon" with central ring to take bolting directly onto underside of headstock

Type 5

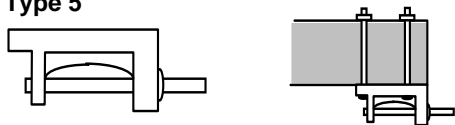
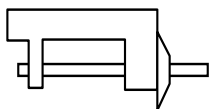

Plate gudgeon - bolts directly onto underside of stock

Type 6



Shield-type, bolt-on Plate gudgeon fitting directly to underside of headstock

Type 7

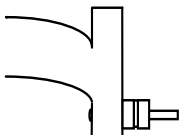

Cast-in integral gudgeon (metal headstock)

Bearings:

Type 1



Socket in horizontal beam or upright post.

Type 2

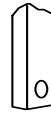

Socket in horizontal steelwork or upright metal strut

Type 3

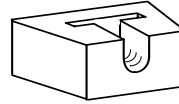

Plain bearing - simple brass or gunmetal plummer block set directly into dovetail mortice

Type 4 - Plain bearing - plummer block mounted in cast-iron pedestal

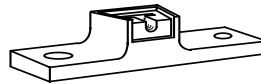

A - flat base

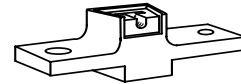

B - dovetail "bossed" base



C - side-fixing

Type 5 A - C

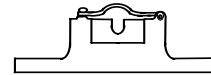

Plain bearing - pedestal mounted plummer block with hinged bearing cover

Type 6 A - C

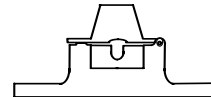

Plain bearing - pedestal mounted plummer block with hinged cover including "chimney" for oiling "wick"

Type 7 A - C

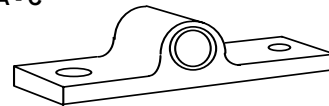

Ball race bearing - heavy pedestal mounting. (as in the style of J. Taylor and Co. of Loughborough)

Type 8 A - C



Ball race bearing - lighter pedestal mounting. (as in the style of Whitechapel Bellfoundry)

Levers and Wheels:

Type 1 - Wooden Lever

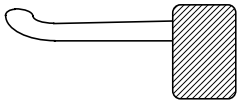

Type 2 - Elongated lever headstock with cross arms

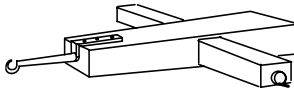

Type 3 - Modern metal lever

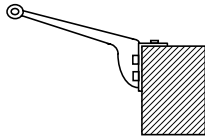

Type 4 - Quarter Wheel

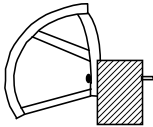

Type 5 - Half wheel

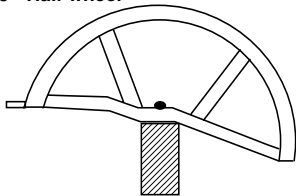

Type 6 - Three quarter wheel

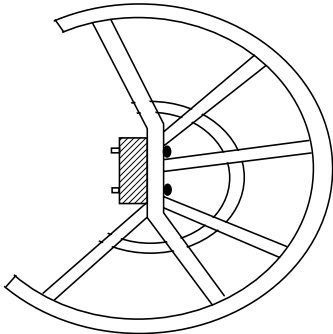

Type 7 - Full Wheel

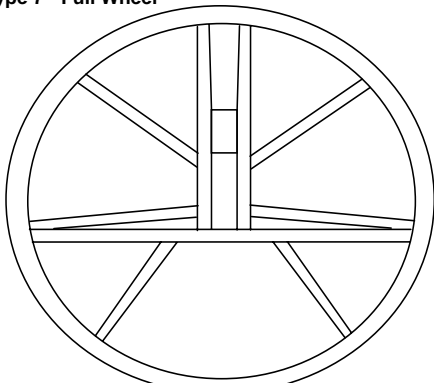

Please indicate diameter of wheel, width of shrouding and spoke arrangement on reverse of proforma

Stays:

Type 1 - Curved ash with bolt and bracket fixing

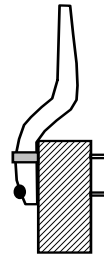

Type 2 - Straight tapered ash for socket fixing.

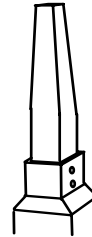

Type 3 - Straight tapered ash for side fixing

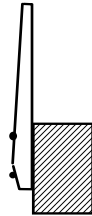

Type 4 - Straight tapered stay fitted with "Hastings" "dingle"

(J Taylor & Co. Loughborough)

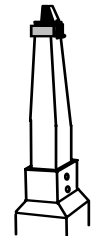

Type 5 - Upright metal hook

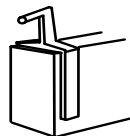

Type 6 - Upright metal peg

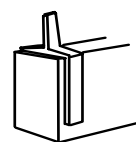

Type 7 - Horizontal metal peg, fixed around headstock

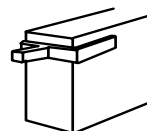

Type 8 - Horizontal metal peg fixed to top of headstock



Sliders:

Type 1 - Straight ash slider and wooden runner board



Type 2 - Steam belt ash slider and wooden runner

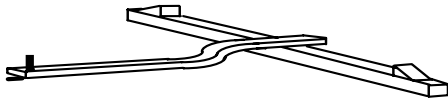

Type 3 - Hastings "quadrant"

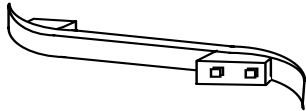

Type 4 - Curved bracket pendulum



Type 5 - Straight pendulum

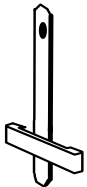

Type 6 - Inverted pendulum

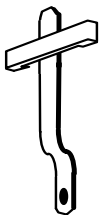

Type 7 - Horizontal latchet

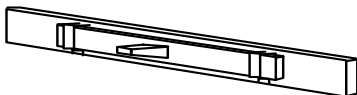

Type 8 - Truck and jockey rail

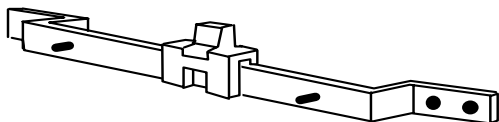

Clappers:

Type 1 - Stirrup head

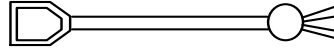

Type 2 - "T" head

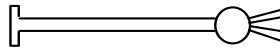

Type 3A - Dovetail spatulate head with oak spacer

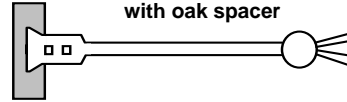

Type 3A - Dovetail spatulate head without spacer



Type 4 - Tapered spatulate head

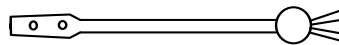

Type 5 - Yoke head and pivot pin

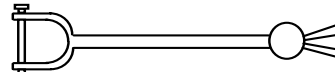

Type 6 - Circular bushed pivot

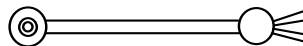

Type 7 - Pear shaped bushed pivot

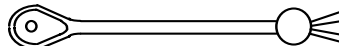

Type 8 - Counterbalanced top

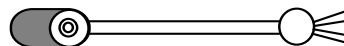

Type A



Enlarged end to shaft

Type B



Flat faced with flight

Type C



Rounded ball, long flight

Type D



"Bun" Ball

Type E



"Doughnut" ball

Type F



Round ball, octagonal flight

Type G



Round ball, rounded flight

Type H



Pear shaped ball

Clapper fixing (if not modern independent type):

Type 1 - Closed ring



Type 2 - "C" link baldrick cope with busk board strut



Type 3 - Coped Busk boards

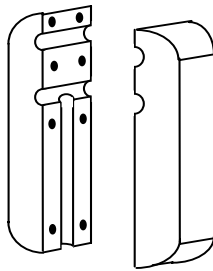

Type 4 - "U" link baldrick cope

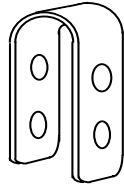

Type 5 - Pivot brackets attached to wooden reversing block

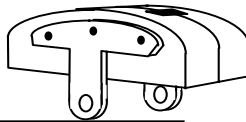

Rope Rollers and Pulleys:

Type 1 - "Spindle" rope roller

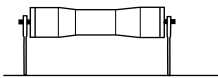

Type 2 - "Cotton reel" rope roller/wooden spindle

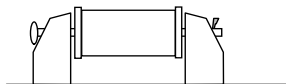

Type 3 - "Early" pulley in enclosed box/wooden spindle

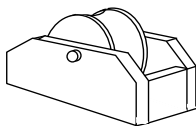

Type 4 - Late 19/early 20th C

- steel spindle, brass bush

A - Single pulley

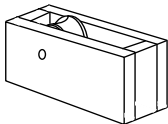

B - Double Pulley

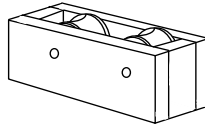

Type 5- Late 19th/early 20thC - lubricated steel spindles, brass bushes

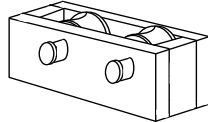
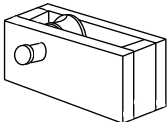

Type 6 - Modern - steel spindles, ball bearings - wooden or nylon sheaves

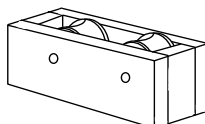
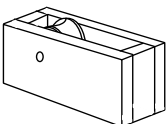

General Description of Bell and Hanging: This section provides scope for clarification diagrams etc. to amplify the points and selections made previously.

Details of How Bell is Used: Please tick the relevant box. "Clocking" is the not to be recommended practice of pulling a clapper into a stationary bell by means of a rope tied around the flight, or similar arrangement.

Additional Information, Sketches etc.: Please use the reverse of the document to record textually or diagrammatically any aspects of the information about each bell and its hangings and fittings that cannot easily be explained elsewhere. Please include variations from the "standard" fitting types given in these notes.

Completed Survey Forms:

Once you have completed a Part 1 Form, and a Part 2 proforma for each bell in the Church, including bells that are not "hung", or disused, you have completed the survey for your Church. Thank you, on behalf of the Winchester and Portsmouth Diocesan Guild of Church Bell Ringers. You have taken part in probably the most comprehensive wide-area survey ever undertaken.

Please feel free to take copies for your local parish records. The completed documents, together with any drawings, photographs or other information you wish to include to amplify the return, should then be forwarded as a complete package to the address below.

If you have problems with the forms: Please contact the address below if you have any queries on the completion of the survey.

If you are unable to complete the survey due to access or other problems: Naturally we would like parishes to make a determined effort to complete their own return since the task is simply too great for the Guild to undertake alone, but if you do have genuine problems such as with access etc. please contact the address below for practical assistance where feasible.

Please address any enquiries, and send the completed survey documents to:

P A G Watts
9 Larkspur Drive
Valley Park
Chandlers Ford
EASTLEIGH
Hants. SO53 4HU
023 80252015 [Home]
023 80792300 [Work]

NB: The information gathered in this survey including contact names and addresses as supplied on the survey forms, will be entered into a computer database for future use by the Winchester and Portsmouth Diocesan Guild of Church Bell Ringers in pursuit of its aims and objectives in regard to the stewardship and use of Church Bells.

Published by the Winchester and Portsmouth Diocesan Guild of Church Bell Ringers.

Master: Barry Fry
General Secretary: Steve Castle, 22 Southcliff Road, Southampton, SO14 6GE

Copyright - The Winchester and Portsmouth Diocesan Guild of Church Bell Ringers.© February 2004